



Bio Instruments S.R.L.

SENSORS AND SYSTEMS
FOR MONITORING GROWING PLANTS

SMTE-M
Soil Moisture Sensor



Description

The SMTE-M Soil Moisture Sensor is a special model of the SMTE-3 Soil Moisture, Temperature and EC Sensor with a single analog output, which represents the dielectric permittivity ϵ of the substrate. The volumetric water content (VWC, %) of the substrate can be calculated by using a soil-specific equation.

Readings

Output signal is a linear representation of the substrate dielectric permittivity ϵ within the range from 1 to 40, that corresponds approximately to 0 to 50% VWC (Volumetric Water Content).

Calibration table:

0 to 2 V output, V	0	2
4 to 20 mA output, mA	4	20
0 to 20 mA output, mA	0	20
ϵ	1	40

Calibration equation:

$$\epsilon = 19.5 * U(V) + 1 \text{ (for 0 to 2 V output)}$$

$$\epsilon = 2.4375 * i(\text{mA}) - 8.75 \text{ (for 4 to 20 mA output)}$$

$$\epsilon = 1.95 * i(\text{mA}) + 1 \text{ (for 0 to 20 mA output)}$$

Equations for calculating VWC (%):

Mineral soil

$$\text{VWC} = 0.00042671 \times \epsilon^3 - 0.054651 \times \epsilon^2 + 2.9086 \times \epsilon - 5.191$$

Sandy soil

$$\text{VWC} = 0.00047463 \times \epsilon^3 - 0.059163 \times \epsilon^2 + 3.0214 \times \epsilon - 8.782$$

Clay soil

$$\text{VWC} = 0.00041983 \times \epsilon^3 - 0.054662 \times \epsilon^2 + 2.9481 \times \epsilon - 3.023$$

Organic substrate

$$VWC = 0.00225 \times \varepsilon^3 - 0.206 \times \varepsilon^2 + 7.24 \times \varepsilon + 24.7$$

Connection diagram

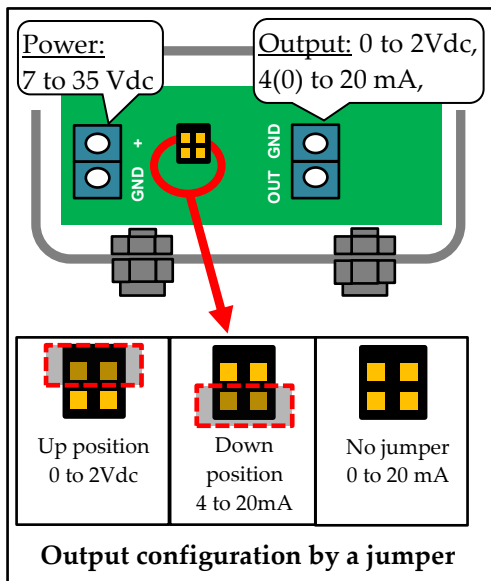

Installation

The SMTE-M sensor can be inserted into soilless substrates in a variety of ways; however, the orientation of the sensor will possibly affect the sensor accuracy. In addition, high spatial variability in soilless substrates will drastically affect the difference between sensor readings from one location to another.

Orientation

The goal of installing a sensor into a substrate is to measure those parameters important to plant growth while not changing them. The SMTE-M can be installed in many different orientations, depending on your needs. However, common sense should be used. For example, installing the sensor in the top of a pot that is being irrigated by micro-sprinkler may cause water to drip around the sensor head, leaving a dry patch of soil immediately below. A better option would be to insert the sensor into the side of the root mass with the needles horizontal, aligned in a vertical row. This will allow water to flow freely through the pot and measurements to be made directly around the roots. Still, when irrigation water is not applied from the surface, it may be entirely appropriate to install the sensor on top of the substrate.

However, please keep in mind that the sensor only measures the VWC in its sphere of influence.

Sensors can either be inserted into the top of the plant pot or into the side of the root ball. Insertion into the side of the root ball may be the best option, as it will give the best indication of the water available to the plant.

Removing the sensors

The SMTE-M is easily removed from substrates. The stainless steel needles slip easily in and out of all types of growing media. Still, we recommend the sensors never be pulled out by their cables, as this can put immense strain on the wires inside. If the sensor is buried, carefully dig down to the sensor, taking care not to damaging the cable with your digging implement. After removing the media around the head, simply grab onto the sensor and remove it.

Cleaning the Probes

1. Clean each pin using a mild detergent such as liquid dish soap and a non-abrasive sponge or cloth.

Note: Avoid detergents that contain lotions or moisturizers.

2. Rinse the sensor and prongs thoroughly with tap or DI water.

Note: Be sure not to touch the prongs with an un-gloved hand or contact them with any source of oil or other non-conducting residue.

Specifications

Measured value:	Substrate dielectric permittivity
Measurement range:	1 to 40
Output:	0 to 2 Vdc, 4 to 20 mA, or 0 to 20 mA, selectable.
Output resolution:	12-bits
Measurement Time:	150 ms
Auto-update time interval:	5 s
Probe Dimensions:	45 x 15 x 145 mm
Prong Length:	70 mm
Power requirements:	7 to 35 Vdc
Operating Temperature:	-40 to +50 °C
Cable length between the probe and the signal conditioner:	3.5 m

Customer Support

If you ever need assistance with your sensor, or if you just have questions or feedback, please e-mail at support@phyto-sensor.com. Please include as part of your message your name, address, phone, and fax number along with a description of your problem.



Bio Instruments S.R.L.

20 Padurii St., Chisinau MD-2002

REPUBLIC OF MOLDOVA

Tel./Fax: +373-22-550026

info@phyto-sensor.com

www.phyto-sensor.com