



Bio Instruments S.R.L.

SENSORS AND SYSTEMS
FOR MONITORING GROWING PLANTS

SMS-5M, SMS-5Mi

Soil Moisture Sensor



Introduction

The SMS-5M sensor measures the dielectric constant of the soil in order to find its volumetric water content. The SMS-5M operates at a high frequency (70 MHz) that allows it to be used in any soil type and in soils with varying degrees of EC (up to 8 dS/m). Its typical accuracy in all soil types without calibration is $\pm 3\%$. With calibration, it is 1–2%.

The SMS-5M sensor has three factory calibrations for Mineral Soil, Potting Soil, and for Rock Wool.

The probe is connected by a standard 5-meter cable to the waterproof box with the signal conditioner inside.

The output cable length should be specified in the order if required.

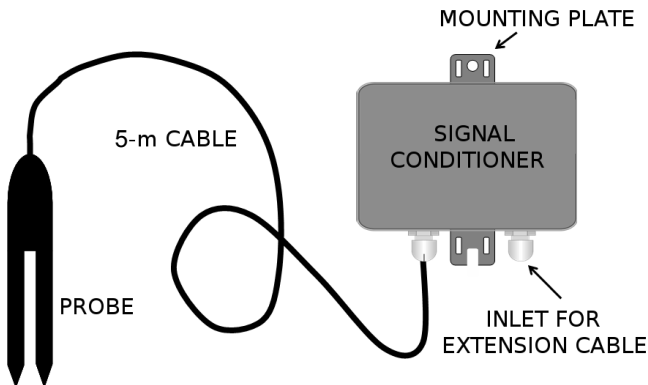

Connection

For models supplied without output cable, please use a four-core cable with 3 to 6 mm outer diameter. The connection diagram is shown in the picture below:

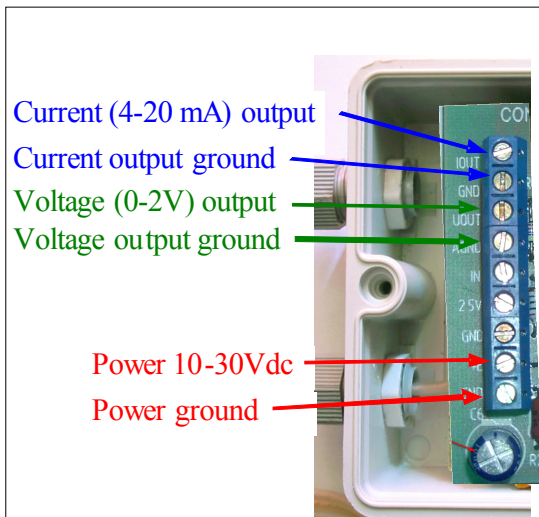

Connection scheme

Maximal length of the output cable is 10 m for sensors with voltage output and up to 200 m for sensors with 4 to 20 and 0 to 20 mA output.

For models supplied with the optional output cable, please refer to a wiring diagram attached to the sensor.

Installation

When installing the sensor's probe, it is important to avoid air gaps or extremely compact soil around the probe, which can skew readings. Do not install the probe next to large metal objects, which can attenuate the probe's electromagnetic field and distort output readings. Because the probe have gaps between their prongs, it is also important to consider the size of the media you are inserting the probe into. It is possible to get sticks, bark, roots or other material stuck between the probe prongs, which will adversely affect readings. Finally, be careful when inserting the probes into dense soil, as the prongs will break if excessive force is used when pushing them in.

The sensor can be inserted directly into growing media or soil. The probe needs to be completely covered by soil. If you have difficulty inserting the probe, try loosening the soil somewhat or wetting the soil. Never pound the probe in. The probes can be oriented in any direction.

Removing the Probes

When removing either probe, do not pull it by the cable! This could break the internal wires and cause the probe to malfunction or not function at all.

Calibrations table

V	mA	VWC, %		
		Mineral Soil	Potting Soil	Rockwool
0.125	5.000			0.3
0.250	6.000			5.1
0.300	6.400		0.2	7.5
0.331	6.650	0.2	1.5	9.0
0.500	8.000	8.3	8.5	18.9
0.750	10.000	20.3	18.9	38.0
1.000	12.000	32.3	29.3	62.5
1.250	14.000	44.3	39.6	92.3
1.306	14.450	47.0	42.0	99.8
1.500	16.000	56.3	50.0	
1.750	18.000		60.4	

Calibrations equations

Mineral soil:

SMS-5M model: $VWC = 119.01 \times U - 40.105$

SMS-5Mi model: $VWC = 6.0006 \times I - 39.729$

Potting soil:

SMS-5M model: $VWC = 103 \times U - 33.396$

SMS-5Mi model: $VWC = 5.1935 \times I - 33.071$

Rockwool:

SMS-5M model: $VWC = 262.93 \times U^2 - 50.659 \times U - 3.9353$

SMS-5Mi model: $VWC = 0.6684 \times I^2 - 2.4705 \times I - 4.0929$

Where

U – output voltage in Volts

I – output current in mA

Output in air:

SMS-5M model: 0 V

SMS-5Mi model: about 4 mA

Output in pure water:

SMS-5M model: 1.4 to 1.5 V

SMS-5Mi model: 15 to 16 mA

Specifications

Measurement	Volumetric Water Content (VWC)	
Range	0 to 100% VWC	
Output	SMS-5M SMS-5Mi	0 to 2 VDC 4 to 20 mA
Accuracy	±3% VWC	
Resolution	0.1% VWC	
Factory calibrations	Mineral Soil, Rockwool, and Potting Soil	
Supply voltage	10 to 30 VDC	
Power	SMS-5M SMS-5Mi	0.5 W max 1 W max
Probe dimensions	89 × 18 × 7 mm	
Protection index of signal conditioner	IP 64	
Cable length between probe and signal conditioner	5 m	



Phyto-Sensor Group

Bio Instruments S.R.L.

20 Padurii St., Chisinau MD-2002

REPUBLIC OF MOLDOVA

Tel./Fax: +373-22-550026

info@phyto-sensor.com

www.phyto-sensor.com